

P2-5 SNAPOUT



P2-5

The P Series

The P series is a medium size, lightweight standard link plastic carrier. Featuring a large window cavity relative to its overall dimensions, the P series is an economical solution to automation and light industrial applications.

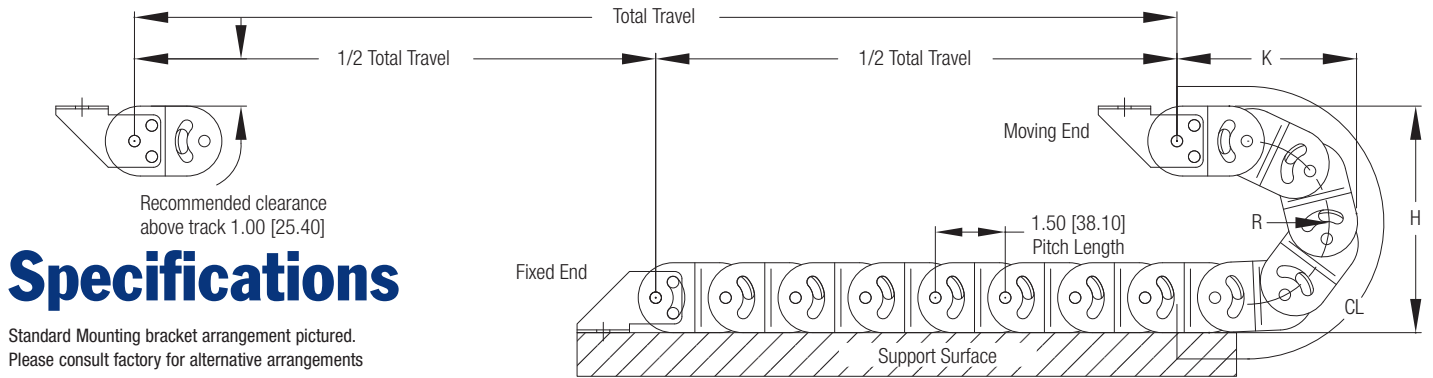

Specifications

Standard Mounting bracket arrangement pictured. Please consult factory for alternative arrangements

Travel/2 + CL (+ Offset Distance From Center*) = Length

* Gortrac recommends mounting the stationary end of the carrier at the center of travel, minimizing the required length. In cases where center mounting is not possible, add the distance offset from center to the carrier length calculation.

Gortrac® Recommends: 10% Cable Clearance
20% Hose Clearance
60% Maximum Fill

How To Create A Part Number: Model # - Height - Length"

Sample Part #: **P1-5-18"**

P Series Design Guide

Model#	A INCHES/mm	C INCHES/mm	Weight #/ft./KG/m
P1	1.25/31.75	1.72/43.69	.35/0.52
P2	2.50/63.50	2.97/75.44	.41/0.61
P3	4.00/101.60	4.47/113.51	.49/0.73

Height	R INCHES/mm	H INCHES/mm	K INCHES/mm	CL INCHES/mm
5	1.75/44.45	5.00/127.00	4.00/101.60	9.0/228.60
10	4.25/107.95	10.00/254.00	6.50/165.10	16.5/419.10

Plastic Crossbars

Plastic cross bars are a lightweight, easily-removable, low-cost option. Quick link cavity access is accomplished with the tip of a screw driver. Many models are available in either top and/or bottom link access.

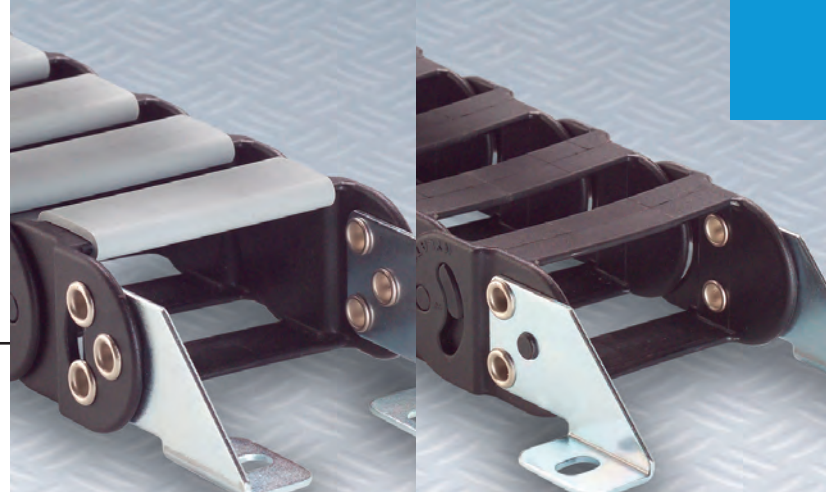

P-SERIES LOAD CHART

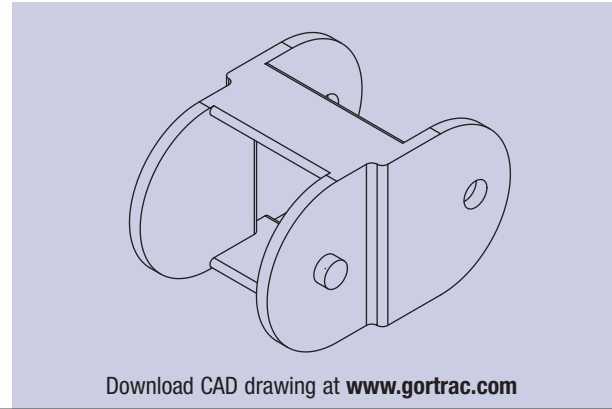
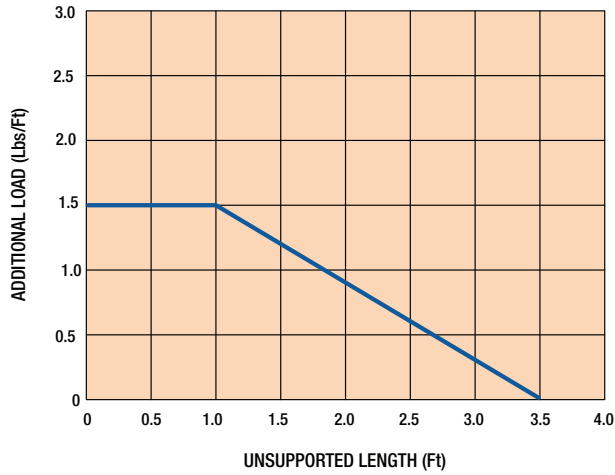

Download CAD drawing at www.gortrac.com

Top View Mounting Hole Dimensions

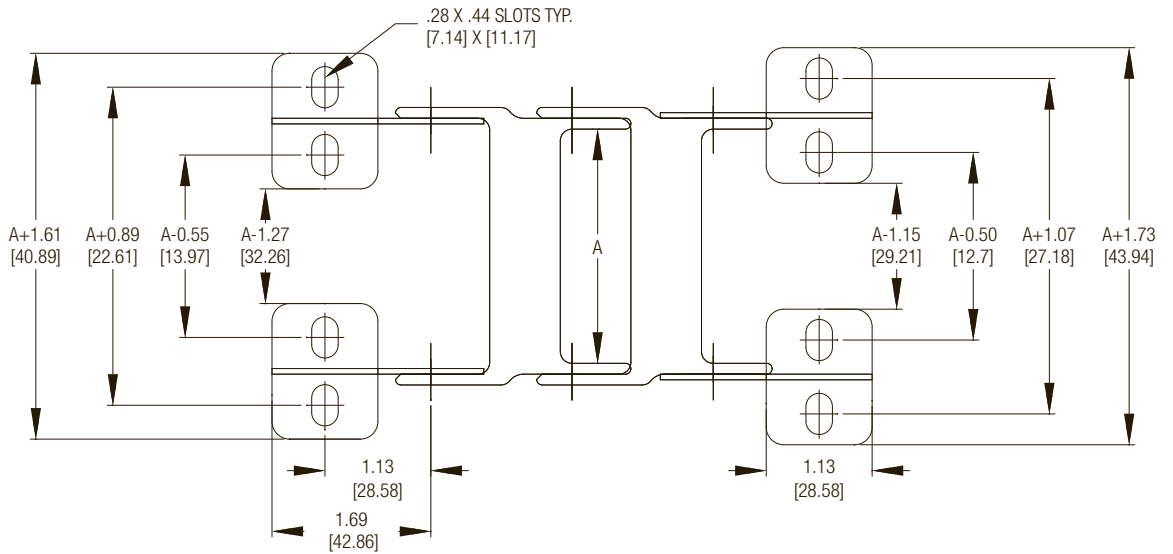

Carrier Cross Sectional View

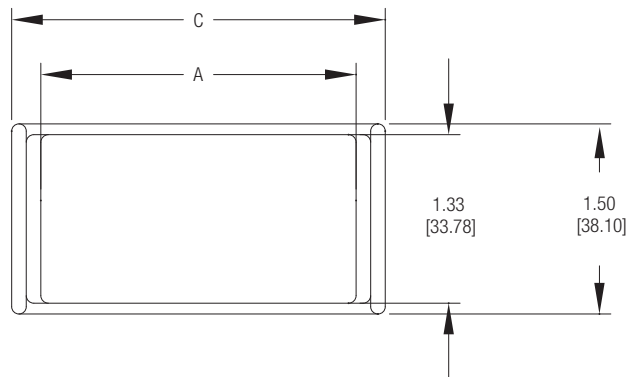

Long Travel Considerations

An important consideration for applications requiring plastic carriers in a guide trough is the bending moment that occurs at the moving end as the carrier is pushing, particularly when high velocities/accelerations and heavy fill weights are introduced.

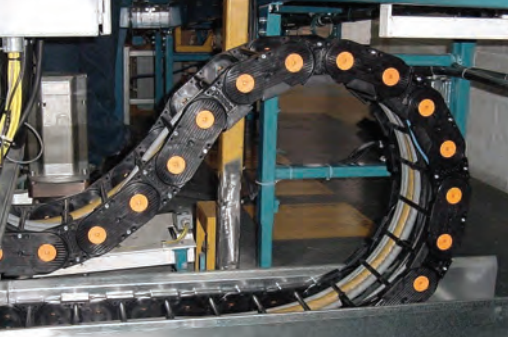

When the carrier performs under normal operation without sag, force is applied in a straight trajectory along the moving section.



As sag is introduced, the mass of the carrier falls below the force plane, creating a bending moment on the links at the moving end.

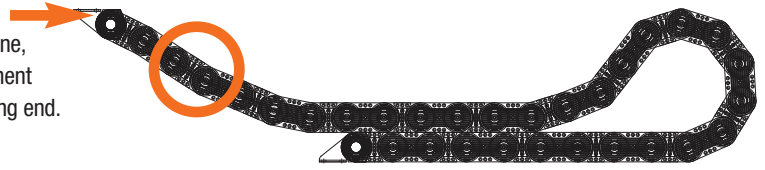

A potential solution for this problem is lowering the mounting height of the carrier, thereby reducing the bending moment. The mounting height is lowered so that the moving end begins gliding immediately as it by adding reverse bending links, extending the "K" dimension of the carrier. Gortrac® Engineering can run tow force calculations on an application to determine whether a lowered mounting height is advisable.

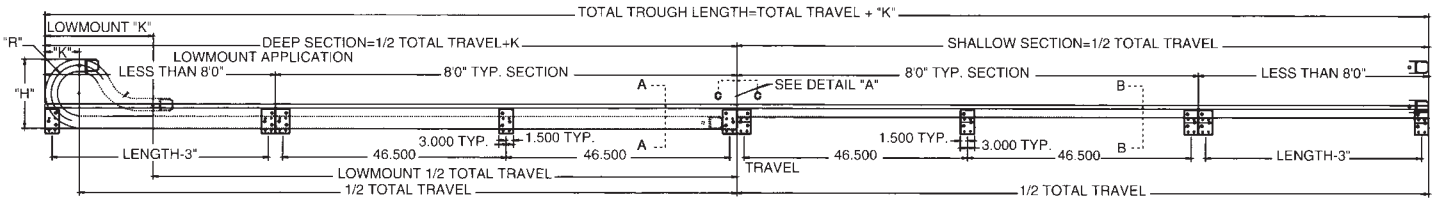
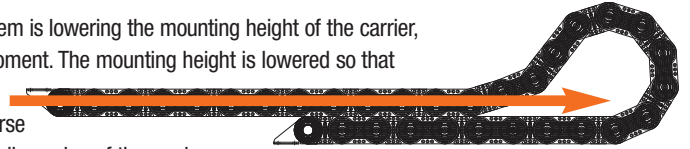

How to Order

Travel/2 + Curve Length (+ Offset Distance From Center*) = Length

* Gortrac recommends mounting the stationary end of the carrier at the center of travel, minimizing the required length. In cases where center mounting is not possible, add the distance offset from center to the carrier length calculation.

Gortrac® Recommends: 10% Cable Clearance
20% Hose Clearance
60% Maximum Fill

How To Create A Part Number: Model # - Height - Number of Separators - Length"

Sample Part #: **KS1-5.4-1-40"**

1. Determine Gortrac cross section desired. Allow 10% clearance over OD's of enclosed cable and 20% over OD's of hoses to prevent binding.
2. Choose radius (Use manufacturer's suggested cable/hose radius).
3. Determine total track length. See the formula above. If fixed flange is not mounted in center of travel, please send a sketch or drawing.

If Gortrac Part Number is known:

Gortrac Part #: _____

Bracket Information (See Page 7 — Standard arrangement and orientation is 1 + IN)
Please check your **arrangement** and **orientation** selection below:

1 2 3 4 IN OUT

If carrier parameters are known:*

Carrier Radius Preferred: _____

Gortrac Model #: _____

Acceleration: _____ Feet/Sec.² Maximum Machine Travel Speed: _____ Feet/Sec.

Frequency of Travel: _____ Cycles/Hour Total Machine Travel: _____ Inches

Gortrac Length (see the formula above): _____

Cable/Hose Load: _____ Operating Temperature: _____ ° F

Environment: _____

If you are currently using another cable carrier, please specify:*

Model #: _____ Length/# of Links: _____

Contact information:

Date: _____ For Quotation Only: _____

Date Required: _____ Quantity: _____

Order Number: _____

Company Name: _____

Attention: _____

Address: _____

City: _____ State/Prov: _____

Country: _____

Zip/Postal Code: _____

Telephone: _____

Fax: _____

E-Mail: _____

Please fax this completed form to the number listed below.

*More information may be required. A Gortrac representative may contact you.