

# The KL Series

The KL series is a medium size standard plastic carrier. It has a rugged design with hinge open bars on the outer radius. The KL series is excellent for machine tool, mobile equipment and moderate industrial applications.

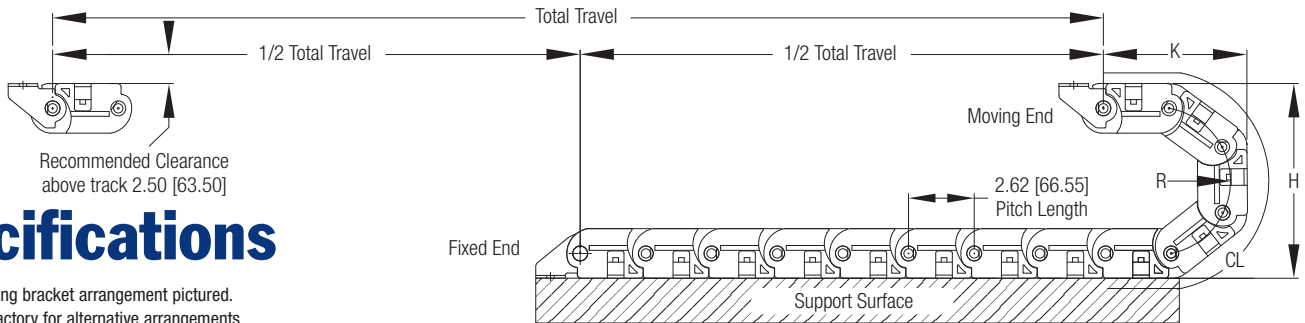
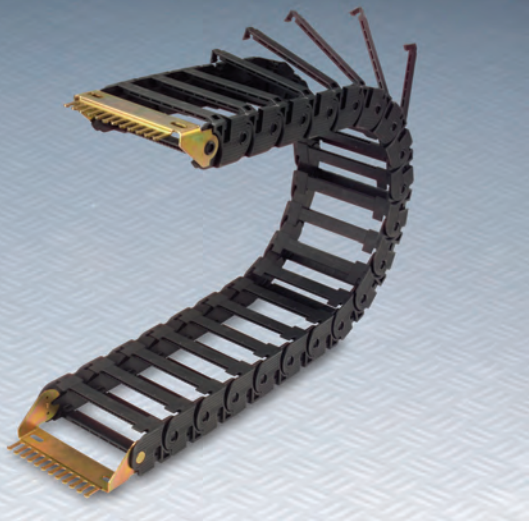

## Specifications

Standard Mounting bracket arrangement pictured.  
Please consult factory for alternative arrangements

**Travel/2 + CL (+ Offset Distance From Center\*) = Length**

\* Gortrac recommends mounting the stationary end of the carrier at the center of travel, minimizing the required length. In cases where center mounting is not possible, add the distance offset from center to the carrier length calculation.

**Gortrac® Recommends:** 10% Cable Clearance  
20% Hose Clearance  
60% Maximum Fill

**How To Create A Part Number: Model # - Height - Number of Separators - Length"**

Sample Part #: **KL1-8.5-1-60"**

## KL Series Design Guide

Model#	A INCHES/mm	C INCHES/mm	Q INCHES/mm	Weight #/Ft. KG/m
KL1	3.00/76.20	3.75/95.25	1.88/47.75	0.98/1.46
KL2	4.50/114.30	5.25/133.35	3.38/85.85	1.11/1.65
KL3	7.00/177.80	7.75/196.85	5.88/149.35	1.48/2.20

Height	R INCHES/mm	H INCHES/mm	K INCHES/mm	CL INCHES/mm
8.5	3.00/76.20	8.50/215.90	6.88/174.75	14.68/372.87
12	4.75/120.65	12.00/304.80	8.63/219.20	20.18/512.57
14	5.75/146.05	14.00/355.60	9.63/244.40	23.31/592.07
18	7.75/196.85	18.00/457.20	11.60/294.64	29.50/749.30
26	11.75/298.45	26.00/660.40	15.60/396.24	42.18/1071.37

## Drop Through

Available as an option in the KL and KS sizes, the drop through access feature allows quick and easy installation and removal of cables and hoses directly through a split, flexible cross bar, eliminating the need for tools or snap-open hinging bars. The Gortrac Drop Through design is unique in that only the access bar itself is flexible. The rest of the link is manufactured from our standard 30% glass-filled plastic, resulting in higher strength and longer unsupported spans.

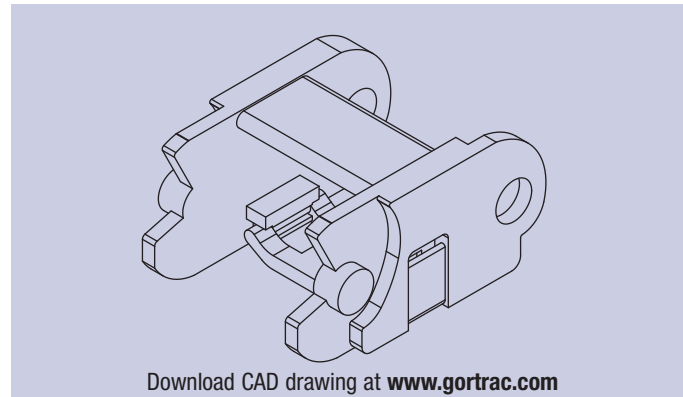
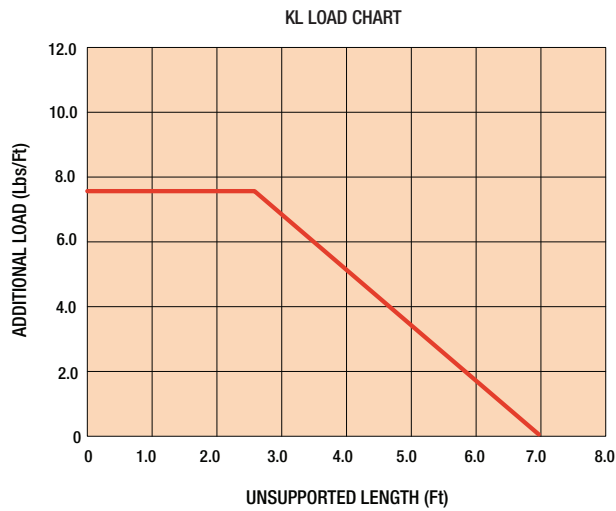
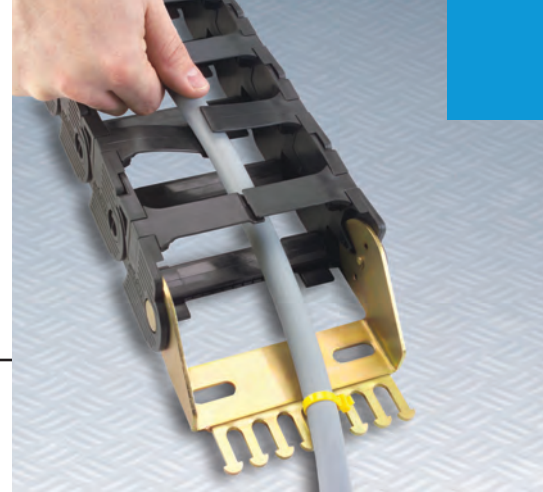

### Top View Mounting Hole Dimensions

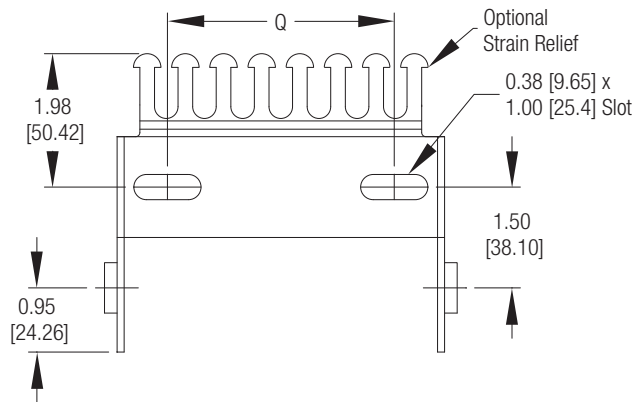

### Carrier Cross Sectional View

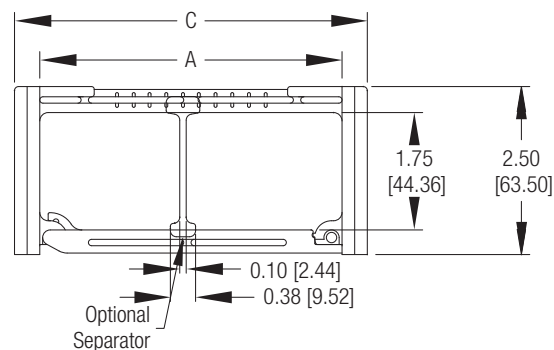

# Long Travel Considerations

An important consideration for applications requiring plastic carriers in a guide trough is the bending moment that occurs at the moving end as the carrier is pushing, particularly when high velocities/accelerations and heavy fill weights are introduced.

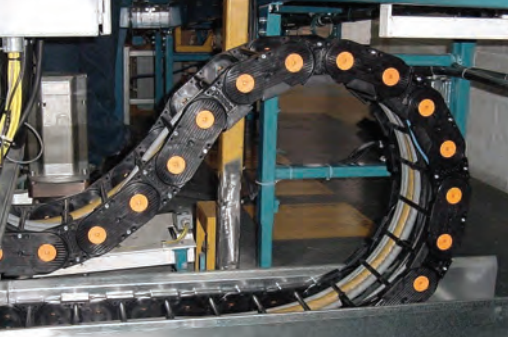

When the carrier performs under normal operation without sag, force is applied in a straight trajectory along the moving section.



As sag is introduced, the mass of the carrier falls below the force plane, creating a bending moment on the links at the moving end.

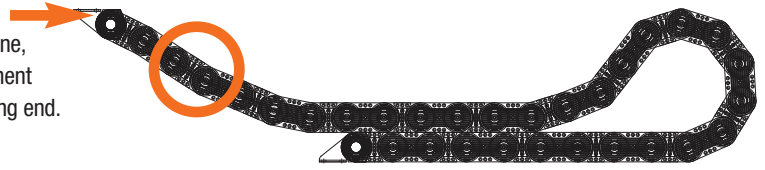

A potential solution for this problem is lowering the mounting height of the carrier, thereby reducing the bending moment. The mounting height is lowered so that the moving end begins gliding immediately as it by adding reverse bending links, extending the "K" dimension of the carrier. Gortrac® Engineering can run tow force calculations on an application to determine whether a lowered mounting height is advisable.

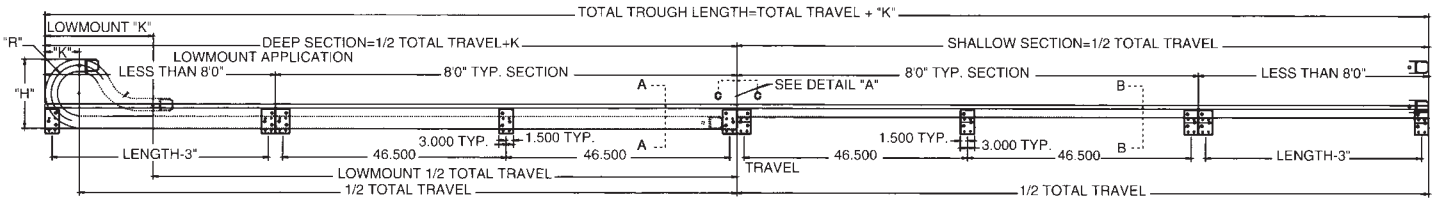
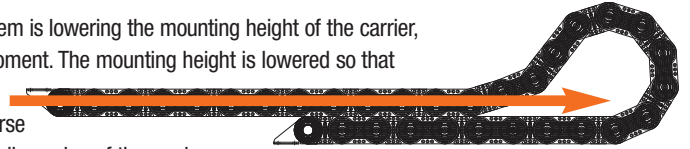

## How to Order

**Travel/2 + Curve Length (+ Offset Distance From Center\*) = Length**

\* Gortrac recommends mounting the stationary end of the carrier at the center of travel, minimizing the required length. In cases where center mounting is not possible, add the distance offset from center to the carrier length calculation.

**Gortrac® Recommends:** 10% Cable Clearance  
20% Hose Clearance  
60% Maximum Fill

**How To Create A Part Number: Model # - Height - Number of Separators - Length"**

Sample Part #: **KS1-5.4-1-40"**

1. Determine Gortrac cross section desired. Allow 10% clearance over OD's of enclosed cable and 20% over OD's of hoses to prevent binding.
2. Choose radius (Use manufacturer's suggested cable/hose radius).
3. Determine total track length. See the formula above. If fixed flange is not mounted in center of travel, please send a sketch or drawing.

**If Gortrac Part Number is known:**

Gortrac Part #: \_\_\_\_\_

Bracket Information (See Page 7 — Standard arrangement and orientation is 1 + IN)  
Please check your **arrangement** and ..... **orientation** selection below:

1  2  3  4  IN  OUT

**If carrier parameters are known:\***

Carrier Radius Preferred: \_\_\_\_\_

Gortrac Model #: \_\_\_\_\_

Acceleration: \_\_\_\_\_ Feet/Sec.<sup>2</sup> Maximum Machine Travel Speed: \_\_\_\_\_ Feet/Sec.

Frequency of Travel: \_\_\_\_\_ Cycles/Hour Total Machine Travel: \_\_\_\_\_ Inches

Gortrac Length (see the formula above): \_\_\_\_\_

Cable/Hose Load: \_\_\_\_\_ Operating Temperature: \_\_\_\_\_ ° F

Environment: \_\_\_\_\_

**If you are currently using another cable carrier, please specify:\***

Model #: \_\_\_\_\_ Length/# of Links: \_\_\_\_\_

**Contact information:**

Date: \_\_\_\_\_ For Quotation Only: \_\_\_\_\_

Date Required: \_\_\_\_\_ Quantity: \_\_\_\_\_

Order Number: \_\_\_\_\_

Company Name: \_\_\_\_\_

Attention: \_\_\_\_\_

Address: \_\_\_\_\_

City: \_\_\_\_\_ State/Prov: \_\_\_\_\_

Country: \_\_\_\_\_

Zip/Postal Code: \_\_\_\_\_

Telephone: \_\_\_\_\_

Fax: \_\_\_\_\_

E-Mail: \_\_\_\_\_

**Please fax this completed form to the number listed below.**

\*More information may be required. A Gortrac representative may contact you.